



TEMP CASA DL

TEMP CASA DL

Input Power	LED Module Options	Color Consistency	Installation Type	Material	Warranty	Beam Angles	Luminaire Color
220 – 240V	CRI 80+ 2700K, 3000K, 3500K, 4000K, 5000K CRI 90+ 2700K, 3000K B.BBL, 3500K B.BBL, 4000K, 5000K	2-Step MacAdam	Recessed, Ceiling mounted	Powder Painted Die-Cast Aluminum	50 000h Or 5 Years	S 15° FL 21° WFL 32° VWFL 46°	White (RAL 9016) Black (RAL 9005)

LED Module Luminous Flux:

Output Current /
Module Wattage /
System Wattage:

	CRI 80+ 3 000K	CRI 80+ 4 000K	CRI 80+ 5 000K	CRI 90+ 2 700K	CRI 90+ 3 000K Below BBL	CRI 90+ 3 500K Below BBL	CRI 90+ 4 000K
300mA / 10W / 11W	1 725Lm	1 800Lm	1 825Lm	1 400Lm	1 375Lm	1 425Lm	1 425Lm
450mA / 15W / 17W	2 475Lm	2 600Lm	2 650Lm	2 025Lm	1 975Lm	2 050Lm	2 250Lm
650mA / 23W / 25W	3 400Lm	3 575Lm	3 625Lm	2 775Lm	2 750Lm	2 850Lm	3 075Lm

Technical Dimensions:

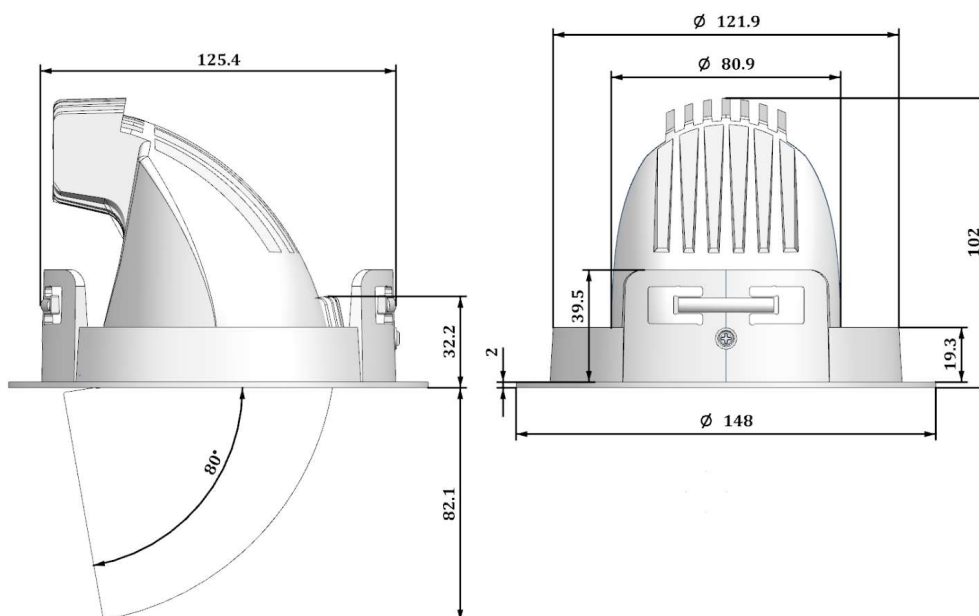

IP20

LED Design | Made In Finland

LIVAL